

REFRIGERATION CONDENSING UNIT



Copeland[®]
brand products

EMERSON[™]
Climate Technologies

EMERSON. CONSIDER IT SOLVED.[™]

Company Profile

Emerson is a global company that brings together technology and engineering to provide innovative solutions for our customers in a wide range of industrial, commercial, and consumer markets. Our priority is to design, produce and deliver products, systems, and solutions that make people's lives better.

Emerson Climate Technologies (India) Limited is offering innovative, energy efficient, environment friendly and reliable compressors, to broad range of customers across India and overseas, for the last four decades.

Fractional and Integral Horse Power Condensing Units provide perfect cooling, creating value for its users. The Condensing Units are manufactured in Atit Plant, which has state-of-the-art facilities and acclaimed to have “Gold Rating” under Emerson's Plant Technology Franchise Standards.

The layout and the performance of the Condensing Units is optimized using CAE facilities. The components are sourced internationally and have been subjected for stringent Qualification Standards of Emerson Climate Technologies. The performance of Condensing Units is validated by testing in a suitable appliance at an ambient of 46°C.

The countrywide Sales and Service network of Emerson Climate Technologies (India) Limited, is positioned to provide prompt service to our customers.



Condenser



- Copiously designed for tropicalized operation
- Bullet expansion for uniform fin bonding

Liquid Line Solenoid Valves

- Pilot operated, 2 way and normally closed type valves



Fan

- Energy efficient & silent fans
- Permanently lubricated bearings
- Suitable for high ambient

Accumulator

- Tested and qualified at application lab
- Handles Flood-back effectively
- Drain hole at bottom for field cleaning if required in future
- Screen for Oil return orifice, making it more reliable



LP-HP Cutout

- Fixed type, cannot be tampered in field
- Proven reliability

Compressor

- Reciprocating / Scroll options
- Very high efficiency
- Rugged & Reliable
- Excellent sound quality
- UL approval & CE mark for many models



Liquid Receiver

- Allows the system to react to widely varying cooling load demands
- With service valve
- Provide reservoir space for refrigerant during operation / servicing

Liquid Line Filter Drier

- Compacted bead type for best performance
- Fibre network filtration element for improved filtration
- Protection to the refrigeration system from moisture and solid contaminants



Moisture Indicator

- With crystal indicator element calibrator in 4 colours



- The above features are available as per BOM chosen by you.
- Customized BOM available on request: Manual HPLP in place of Fixed Type, Front and Rear Grills, Dry Fabric Filter, Glands etc.



Integral Horse Power Condensing Units

R22

Model	Ambient Temperature (°C)	Evaporating Temperature (°C)											
		Capacity (kW)						Power (kW)					
		-6.7	-1.1	4.4	7.2	10	12.8	-6.7	-1.1	4.4	7.2	10	12.8
KHJ513PAE	35	2.21	2.70	3.38	3.75	4.17	4.64	1.34	1.41	1.48	1.52	1.56	1.60
	43	1.96	2.38	3.02	3.37	3.79	4.28	1.39	1.47	1.55	1.59	1.63	1.67
	46	-	2.28	2.90	3.25	3.67	4.16	-	1.49	1.57	1.61	1.65	1.69
KHR522PAE	35	3.40	4.27	5.22	5.74	6.31	6.91	1.56	1.68	1.78	1.83	1.89	1.94
	43	2.87	3.66	4.51	4.98	5.47	6.00	1.58	1.74	1.87	1.94	2.00	2.07
	46	2.69	3.46	4.27	4.71	5.18	5.69	1.58	1.75	1.89	1.96	2.04	2.11
KHR522MAE	35	3.40	4.27	5.22	5.74	6.31	6.91	1.56	1.68	1.78	1.83	1.89	1.94
	43	2.87	3.66	4.51	4.98	5.47	6.00	1.58	1.74	1.87	1.94	2.00	2.07
	46	2.69	3.46	4.27	4.71	5.18	5.69	1.58	1.75	1.89	1.96	2.04	2.11
KHR530PAE	35	4.18	5.28	6.41	6.97	7.57	8.15	1.88	2.09	2.28	2.36	2.42	2.48
	43	3.50	4.51	5.56	6.10	6.63	7.16	1.92	2.18	2.41	2.51	2.60	2.68
	46	3.28	4.27	5.29	5.81	6.33	6.84	1.93	2.19	2.44	2.54	3.64	2.72
KHR530MAE	35	4.18	5.28	6.41	6.97	7.57	8.15	1.88	2.09	2.28	2.36	2.42	2.48
	43	3.50	4.51	5.56	6.10	6.63	7.16	1.92	2.18	2.41	2.51	2.60	2.68
	46	3.28	4.27	5.29	5.81	6.33	6.84	1.93	2.19	2.44	2.54	2.64	2.72
KHR536PAE	35	5.26	6.56	7.92	8.61	9.32	10.03	2.09	2.50	2.67	2.74	2.80	2.86
	43	4.48	5.70	6.96	7.59	8.23	8.89	2.38	2.64	2.88	2.80	3.07	3.15
	46	4.22	5.41	6.64	7.26	7.88	8.52	2.39	2.68	2.94	3.05	3.15	3.24
KHR536MAE	35	5.22	6.51	7.84	8.53	9.23	9.94	2.32	2.53	2.71	2.78	2.85	2.91
	43	4.45	5.65	6.89	7.52	8.16	8.81	2.40	2.67	2.91	3.01	3.10	3.18
	46	4.19	5.37	6.58	7.19	7.81	8.44	2.41	2.71	2.97	3.08	3.18	3.27
KHR542PAE	35	5.98	7.40	8.93	9.74	10.54	11.39	2.65	2.95	3.23	3.35	3.46	3.55
	43	5.15	6.42	7.78	8.45	9.24	9.96	2.74	3.09	3.42	3.57	3.69	3.80
	46	4.87	6.08	7.38	8.02	8.79	9.47	2.76	3.13	3.47	3.62	3.75	3.86
KHR542MAE	35	5.98	7.40	8.93	9.74	10.54	11.39	2.65	2.95	3.23	3.35	3.46	3.55
	43	5.15	6.42	7.78	8.45	9.24	9.96	2.74	3.09	3.42	3.57	3.69	3.80
	46	4.87	6.08	7.38	8.02	8.79	9.47	2.76	3.13	3.47	3.62	3.75	3.86
KHG554PBE	35	7.83	9.92	12.29	13.58	14.87	16.15	3.47	4.21	4.63	4.76	4.88	5.00
	43	6.41	8.37	10.52	11.69	12.83	13.89	3.60	4.41	4.87	5.02	5.15	5.29
	46	5.98	7.86	9.89	10.98	12.08	13.07	3.66	4.49	4.97	5.13	5.26	5.40
KHG554MAE	35	7.83	9.92	12.29	13.58	14.87	16.15	3.47	4.21	4.63	4.76	4.88	5.00
	43	6.41	8.37	10.52	11.69	12.83	13.89	3.60	4.41	4.87	5.02	5.15	5.29
	46	5.98	7.86	9.89	10.98	12.08	13.07	3.66	4.49	4.97	5.13	5.26	5.40
KHG562PBE	35	9.01	11.75	13.97	15.21	16.51	18.25	4.37	4.55	5.24	5.58	5.84	5.90
	43	7.18	9.86	11.98	13.10	14.35	15.84	4.45	4.68	5.45	5.86	6.18	6.36
	46	-	9.30	11.38	12.44	13.65	15.12	-	4.71	5.53	5.97	6.33	6.55
KHG562MAE	35	9.01	11.75	13.97	15.21	16.51	18.25	4.37	4.55	5.24	5.58	5.84	5.90
	43	7.18	9.86	11.98	13.10	14.35	15.84	4.45	4.68	5.45	5.86	6.18	6.36
	46	-	9.30	11.38	12.44	13.65	15.12	-	4.71	5.53	5.97	6.33	6.55
KHG572PBE	35	9.84	12.98	15.50	16.95	18.42	20.35	5.03	5.43	6.15	6.54	6.93	7.24
	43	8.07	10.98	13.04	14.16	15.46	17.01	5.18	5.60	6.34	6.75	7.12	7.44
	46	-	9.90	11.92	13.03	14.19	15.52	-	5.66	6.40	6.80	7.18	7.51
KHG572MAE	35	10.16	13.36	15.93	17.51	19.18	21.31	5.01	5.38	6.09	6.48	6.85	7.15
	43	8.49	11.57	13.92	15.21	16.54	18.36	5.15	5.56	6.29	6.68	7.06	7.38
	46	-	10.66	12.82	14.03	15.40	17.05	-	5.62	6.36	6.75	7.13	7.44
KHZ572PAE	35	11.38	13.69	16.14	17.42	18.72	20.05	5.03	5.13	5.24	5.29	5.35	5.40
	43	-	12.28	14.55	15.73	16.93	18.08	-	6.11	6.20	6.24	6.28	6.32
	46	-	11.77	13.98	15.13	16.30	17.48	-	6.48	6.57	6.60	6.64	6.67
KHZ572MAE	35	11.4	13.7	16.1	17.4	18.7	20.0	5.03	5.13	5.24	5.29	5.35	5.40
	43	-	12.3	14.6	15.7	16.9	18.1	-	6.11	6.20	6.24	6.28	6.32
	46	-	11.8	14.0	15.1	16.3	17.5	-	6.48	6.57	6.60	6.64	6.67
KHZ581PAE	35	12.84	15.47	18.26	19.72	21.18	22.65	5.64	5.77	5.90	5.95	6.00	6.05
	43	-	13.99	16.48	17.82	19.20	20.59	-	6.73	6.84	6.90	6.95	6.99
	46	-	13.33	15.84	17.15	18.49	19.84	-	7.09	7.20	7.25	7.29	7.33
KHZ581MAE	35	12.84	15.47	18.26	19.72	21.18	22.65	5.64	5.77	5.90	5.95	6.00	6.05
	43	-	13.88	16.48	17.82	19.20	20.59	-	6.73	6.84	6.90	6.95	6.99
	46	-	13.33	15.84	17.15	18.49	19.84	-	7.09	7.20	7.25	7.29	7.33

Fractional Horse Power Condensing Units

R134a , R22

Model	Ambient Temperature (°C)	Evaporating Temperature (°C)											
		Capacity (kW)					Power (kW)						
R134a - Low Temperature		-28.9	-23.3	-17.8	-12.2	-6.7	-28.9	-23.3	-17.8	-12.2	-6.7		
KFN372LAG	32	0.15	0.21	0.28	0.36	0.45	0.16	0.18	0.21	0.23	0.26		
	43	0.13	0.18	0.25	0.33	0.42	0.16	0.19	0.21	0.24	0.28		
KFN396LAG	35	0.17	0.24	0.31	0.37	0.43	0.17	0.19	0.21	0.24	0.27		
	43	0.14	0.20	0.25	0.31	0.36	0.17	0.20	0.22	0.25	0.28		
KFJ411LAG	46	0.14	0.19	0.24	0.29	0.33	0.17	0.20	0.23	0.25	0.29		
	32	0.23	0.32	0.43	0.55	0.69	0.26	0.30	0.35	0.43	0.51		
KFJ412LAG	43	0.15	0.24	0.33	0.43	0.55	0.24	0.29	0.36	0.45	0.53		
	32	0.27	0.37	0.50	0.65	0.83	0.31	0.34	0.39	0.46	0.54		
KFN415LAG	43	0.17	0.27	0.38	0.52	0.68	0.32	0.35	0.40	0.48	0.56		
	32	0.30	0.43	0.57	0.71	0.86	0.32	0.36	0.40	0.43	0.47		
	43	0.23	0.34	0.46	0.59	0.73	0.33	0.37	0.41	0.46	0.50		
	R134a - High and Medium Temperature		Evaporating Temperature (°C)										
		-6.7	-1.1	4.4	7.2	10.0	12.8	-6.7	-1.1	4.4	7.2	10.0	12.8
KFE419HAG	35	0.26	0.31	0.39	0.44	0.50	0.58	0.17	0.19	0.22	0.24	0.26	0.27
	43	0.22	0.27	0.34	-	-	-	0.17	0.20	0.23	-	-	-
	46	0.21	-	-	-	-	-	0.18	-	-	-	-	-
KFE432HAG	35	0.54	0.66	0.84	0.99	1.20	1.38	0.66	0.68	0.70	0.71	0.72	0.74
	43	0.46	0.57	0.75	0.88	1.00	1.25	0.67	0.70	0.72	0.74	0.75	0.76
	46	4.33	0.54	0.71	0.84	1.00	1.21	0.68	0.70	0.70	0.73	0.76	0.77
KFE444HAG	35	0.60	0.74	0.94	1.08	1.20	1.41	0.36	0.40	0.44	0.47	0.49	0.52
	43	0.52	0.63	0.81	0.92	1.10	1.21	0.37	0.41	0.46	0.49	0.53	0.56
	46	0.49	0.61	0.77	0.87	1.00	1.15	0.38	0.42	0.47	0.50	0.54	0.57
KFJ444HAG	35	0.54	0.70	0.93	1.08	1.30	1.46	0.34	0.38	0.42	0.44	0.47	0.50
	43	0.47	0.59	0.79	0.91	1.10	1.23	0.36	0.40	0.45	0.48	0.50	0.54
	46	0.45	0.56	0.74	0.86	1.00	1.17	0.37	0.41	0.46	0.49	0.51	0.55
KFJ467HAG	35	0.90	1.14	1.42	1.57	1.70	1.90	0.54	0.58	0.65	0.70	0.77	0.88
	43	0.77	0.98	1.23	1.37	1.50	1.67	0.56	0.61	0.68	0.73	0.81	0.92
	46	0.72	0.93	1.17	1.30	1.40	1.59	0.57	0.62	0.69	0.75	0.82	0.93
KFN463HAG	35	0.89	1.08	1.32	1.46	1.60	1.80	0.53	0.56	0.60	0.62	0.64	0.65
	43	0.82	0.99	1.20	1.32	1.40	1.60	0.55	0.59	0.64	0.66	0.67	0.68
R22 - High and Medium Temperature		Evaporating Temperature (°C)											
		-6.7	-1.1	4.4	7.2	10.0	12.8	-6.7	-1.1	4.4	7.2	10.0	12.8
KFE443HAE	35	0.64	0.82	1.03	1.09	1.30	1.46	0.45	0.46	0.49	0.51	0.52	0.54
	43	0.54	0.70	0.89	0.99	1.10	1.28	0.47	0.49	0.52	0.54	0.55	0.57
	46	0.51	0.66	0.84	0.94	1.10	1.22	0.48	0.50	0.52	0.54	0.56	0.58
KFE461HAE	35	0.91	1.16	1.45	1.60	1.80	1.92	0.59	0.62	0.69	0.74	0.79	0.85
	43	0.79	0.99	1.26	1.41	1.60	1.74	0.61	0.65	0.73	0.78	0.83	0.88
	46	0.76	0.95	1.20	1.36	1.50	1.70	0.62	0.66	0.74	0.79	0.84	0.89
KFJ511HAE	35	1.60	1.85	2.51	2.91	3.30	3.63	0.88	0.88	0.98	1.06	1.14	1.21
	43	1.35	1.55	2.17	2.53	2.90	3.20	0.92	0.93	1.04	1.12	1.19	1.27
	46	1.29	1.46	2.06	2.42	2.80	3.06	0.93	0.95	1.06	1.13	1.21	1.28

Scope of Supply: Integral Horse Power Condensing Unit

Condensing Unit Model	Compressor Used	Standard Scope	Add Ons
KHJ513PAE-B30820	KCJ513HAE-B420	Compressor, Condenser with front grill, Fan with Base Plate, Prewired Junction Box, HP-LP Cutout, Liquid line Filter Drier.	Expansion valve and cage, Solenoid valve, Moisture indicator, Canopy with rear grill.
KHR522PAE-B30820	CR22K6M-PF1-131	Compressor, Condenser with front grill, Fan with Protection grill, Base Plate, Prewired Junction Box, HP-LP Cutout, Liquid line Filter Drier.	Expansion valve and cage, Solenoid valve, Moisture indicator, Canopy with rear grill.
KHR522MAE-B37D21	CR22K6M-PF1-131	Compressor, Condenser with front grill, Fan with Protection grill, Base plate, Prewired Junction Box, HP-LP Cutout, Liquid Line Filter Drier, Standard Mounting Legs, Canopy with rear grill.	Expansion valve with Cage.
KHR530MAE-B37D21	CR30K6M-PF1-131	Compressor, Condenser with front grill, Fan with Protection grill, Base plate, Prewired Junction Box, HP-LP Cutout, Liquid Line Filter Drier, Standard Mounting Legs, Canopy with rear grill.	Expansion valve with Cage.
KHR530PAE-B30820	CR30K6M-PF1-131	Compressor, Condenser with front grill, Fan with Protection grill, Base Plate, Prewired Junction Box, HP-LP Cutout, Liquid line Filter Drier.	Expansion valve and cage, Solenoid valve, Moisture indicator, Canopy with rear grill.
KHR536PAE-D50820	CR36K6-TF6-101	Compressor, Condenser with front grill, Fan with Protection grill, Base Plate, Prewired Junction Box, HP-LP Cutout, Liquid line Filter Drier.	Receiver, Expansion valve and cage, Solenoid valve, Moisture indicator, Canopy with rear grill.
KHR536PAE-F30820	CR36K6-PFZ-121	Compressor, Condenser with front grill, Fan with Protection grill, Base Plate, Prewired Junction Box, HP-LP Cutout, Liquid line Filter Drier.	Receiver, Expansion valve and cage, Solenoid valve, Moisture indicator, Canopy with rear grill.
KHR536MAE-F37D21	CR36K6-PFZ-121	Compressor, Condenser with front grill, Fan with Protection grill, Base plate, Prewired Junction box, HP-LP Cutout, Receiver, Liquid Line Filter Drier, Solenoid Valve, Moisture Indicator, Standard Mounting Legs, Canopy.	Expansion valve with Cage.
KHR536MAE-D57D21	CR36K6-TF6-101	Compressor, Condenser with front grill, Fan with Protection grill, Base plate, Prewired Junction box, HP-LP Cutout, Receiver, Liquid Line Filter Drier, Solenoid Valve, Moisture Indicator, Standard Mounting Legs, Canopy.	Expansion valve with Cage.
KHR542MAE-D57D21	CR42K6-TF6-101	Compressor, Condenser with front grill, Fan with Protection grill, Base plate, Prewired Junction box, HP-LP Cutout, Receiver, Liquid Line Filter Drier, Solenoid Valve, Moisture Indicator, Standard Mounting Legs, Canopy.	Expansion valve with Cage.
KHR542PAE-D50820	CR42K6-TF6-101	Compressor, Condenser with front grill, Fan with Protection grill, Base Plate, Prewired Junction Box, HP-LP Cutout, Liquid line Filter Drier.	Receiver, Expansion valve and cage, Solenoid valve, Moisture indicator, Canopy with rear grill.
KHG554MAE-D5FDA1	KCG554HAE-D512	Compressor with service valve, Condenser with front grill, Fan with Protection grill, Base plate, Prewired Junction Box, HP-LP Cutout, Receiver, Liquid Line Filter Drier, Solenoid Valve, Moisture Indicator, Standard Mounting Legs, Suction Accumulator, Canopy with Rear grill.	Expansion valve with Cage.
KHG554PBE-D588A0	KCG554HAE-D512	Compressor with service valve, Condenser with front grill, Fan with Protection grill, Base Plate, Prewired Junction Box, HP-LP Cutout, Liquid line Filter Drier, Suction Accumulator.	Expansion valve and cage, Solenoid valve, Moisture indicator, Canopy with rear grill.

Scope of Supply: Integral Horse Power Condensing Unit

Condensing Unit Model	Compressor Used	Standard Scope	Add Ons
KHG562MAE-D5FDA1	KCG562HAE-D512	Compressor with service valve, Condenser with front grill, Fan with Protection grill, Base plate, Prewired Junction Box, HP-LP Cutout, Receiver, Liquid Line Filter Drier, Solenoid Valve, Moisture Indicator, Standard Mounting Legs, Suction Accumulator, Canopy with Rear grill.	Expansion valve with Cage.
KHG562PBE-D588A0	KCG562HAE-D512	Compressor with service valve, Condenser with front grill, Fan with Protection grill, Base Plate, Prewired Junction Box, HP-LP Cutout, Liquid line Filter Drier, Suction Accumulator.	Expansion valve and cage, Solenoid valve, Moisture indicator, Canopy with rear grill.
KHR563MAE-E57DA1	CRNQ0500-TFD-523	Compressor with service valve, Condenser with front grill, Fan with Protection grill, Base plate, Prewired Junction Box, HP-LP Cutout, Receiver, Liquid Line Filter Drier, Solenoid Valve, Moisture Indicator, Standard Mounting Legs, Canopy with Rear grill.	Expansion valve with Cage.
KHR563PAE-E508A0	CRNQ0500-TFD-523	Compressor with service valve, Condenser with front grill, Fan with Protection grill, Base Plate, Prewired Junction Box, HP-LP Cutout, Liquid line Filter Drier.	Receiver, Expansion valve and cage, Solenoid valve, Moisture indicator, Canopy with rear grill.
KHG572MAE-D5FDA1	KCG572HAE-D512	Compressor with service valve, Condenser with front grill, Fan with Protection grill, Base plate, Prewired Junction Box, HP-LP Cutout, Receiver, Liquid Line Filter Drier, Solenoid Valve, Moisture Indicator, Standard Mounting Legs, Suction Accumulator, Canopy with Rear grill.	Expansion valve with Cage.
KHG572PBE-D588A0	KCG572HAE-D512	Compressor with service valve, Condenser with front grill, Fan with Protection grill, Base Plate, Prewired Junction Box, HP-LP Cutout, Liquid line Filter Drier, Suction line Accumulator.	Expansion valve and cage, Solenoid valve, Moisture indicator, Canopy with rear grill.
KHZ572MAE-E57D61	ZB45KQ-TFD-524	Compressor with service valve, Condenser with front grill, Fan with Protection grill, Base plate, Prewired Junction box, HP-LP Cutout, Receiver, Liquid Line Filter Drier, Solenoid Valve, Moisture Indicator, Standard Mounting Legs, Canopy.	Expansion valve with Cage.
KHZ572PAE-E50820	ZB45KQ-TFD-524	Compressor, Condenser with front grill, Fan with Protection grill, Base Plate, Prewired Junction Box, HP-LP Cutout, Liquid line Filter Drier.	Receiver, Expansion valve and cage, Solenoid valve, Moisture indicator, Canopy with rear grill.
KHZ581MAE-E57D61	ZB48KQ-TFD-524	Compressor with service valve, Condenser with front grill, Fan with Protection grill, Base plate, Prewired Junction box, HP-LP Cutout, Receiver, Liquid Line Filter Drier, Solenoid Valve, Moisture Indicator, Standard Mounting Legs, Canopy.	Expansion valve with Cage.
KHZ581PAE-E50820	ZB48KQ-TFD-524	Compressor, Condenser with front grill, Fan with Base Plate, Prewired Junction Box, HP-LP Cutout, Liquid line Filter Drier.	Receiver, Expansion valve and cage, Solenoid valve, Moisture indicator, Canopy with rear grill.

Scope of Supply: Fractional Horse Power Condensing Unit

Condensing Unit Model	Standard Scope	Add On
All Fractional Horse Power Condensing Unit	Compressor, Condenser, Fan, Base Plate, Accessory Box or mount on accessory	Liquid line drier

Technical Data

Condensing Unit Model	Compressor Model	Dimensions L X H X W (mm)	Appx Weight (kg)	Suction Line (OD) Liquid Line (OD)	Compressor RLA (A) LRA (A)	Fan RLA (A)	Fan RPM No. of Fans	Total Airflow (CFM)
R-22 High Temperature – Integral Horse Power Condensing Units								
KHJ513PAE-B30820	KCJ513HAE-B420	653 X 470 X 667	90.0	1/2" 3/8"	6.80 30.00	0.54	1200 1	1400
KHR522PAE-B30820	CR22K6M-PF1-131	575 X 625 X 815	110.0	5/8"	7.80	0.58	1200	1400
KHR522MAE-B37D21		586 X 625 X 820		3/8"	54.00		1	
KHR530PAE-B30820	CR30K6M-PF1-131	575 X 625 X 815	110.0	3/4"	11.00	0.58	1200	1400
KHR530MAE-B37D21		586 X 625 X 820		3/8"	72.00		1	
KHR536PAE-D50820	CR36K6-TF6-101	704 X 685 X 891	140.0	3/4"	4.90	1.00	1200	1800
KHR536MAE-D57D21		793 X 685 X 935		3/8"	41.00		1	
KHR536PAE-F30820	CR36K6-PFZ-121	704 X 685 X 891	140.0	3/4"	13.60	1.00	1200	1800
KHR536MAE-F37D21		793 X 685 X 935		3/8"	85.00		1	
KHR542PAE-D50820	CR42K6-TF6-101	704 X 685 X 891	140.0	3/4"	6.10	1.00	1200	1800
KHR542MAE-D57D21		780 X 685 X 935		3/8"	45.00		1	
KHG554PBE-D588A0	KCG554HAE-D512	776 X 690 X 1200	200.0	7/8"	7.20	1.00	1200	3600
KHG554MAE-D5FDA1		785 X 690 X 1200		1/2"	44.00		2	
KHG562PBE-D588A0	KCG562HAE-D512	776 X 690 X 1200	200.0	7/8"	8.50	1.00	1200	3600
KHG562MAE-D5FDA1		785 X 690 X 1200		1/2"	49.00		2	
KHR563PAE-E508A0	CRN0500-TFD-523	776 X 690 X 1200	180.0	7/8"	8.60	1.00	1200	3600
KHR563MAE-E57DA1		785 X 690 X 1200		1/2"	65.00		2	
KHG572PBE-D588A0	KCG572HAE-D512	655 X 676 X 1048	200.0	7/8"	10.20	1.10	1200	3400
KHG572MAE-D5FDA1		785 X 690 X 1200		1/2"	55.00		2	3600
KHZ572PAE-E50820	ZB45KQ-TFD-524	770 X 742 X 1358	200.0	7/8"	10.00	1.00	1200	3600
KHZ572MAE-E57D61		785 X 742 X 1348		1/2"	74.00		2	
KHZ581PAE-E50820	ZB48KQ-TFD-524	770 X 742 X 1358	200.0	7/8"	12.00	1.20	1200	4300
KHZ581MAE-E57D61		785 X 742 X 1348		1/2"	101.00		2	
R-134a - Low Temperature – Fractional Horse Power Condensing Units								
KFN372LAG-B20000	KCN372LAG-B230	412 X 250 X 285	18.5	5/16" 3/8"	1.30 10.00	0.28	1300 1	250
KFN396LAG-B20000	KCN396LAG-B230	404 X 250 X 285	19.5	5/16" 3/8"	1.85 10.20	0.28	1300 1	250
KFJ411LAG-B20000	KCJ411LAG-B220	390 X 286 X 343	26.0	1/2" 3/8"	2.20 22.00	0.28	1300 1	250
KFJ412LAG-B20000	KCJ412LAG-B220	401 X 330 X 356	26.0	1/2" 3/8"	2.75 24.00	0.40	1300 1	350
KFN415LAG-B30000	KCN415LAG-B330	401 X 330 X 356	21.5	5/16" 3/8"	2.00 14.00	0.40	1300 1.0	350
R-134a - High & Medium Temperature – Fractional Horse Power Condensing Units								
KFE419HAG-B10000	KCE419HAG-B330	352 X 250 X 290	17.8	1/4" 3/8"	1.60 11.00	0.28	1300 1	250
KFE432HAG-B20000	KCE432HAG-B230	457 X 305 X 343	22.0	5/16" 3/8"	2.80 12.50	0.45	1300 1	450
KFE444HAG-B30000	KCE444HAG-B330	457 X 305 X 343	22.0	5/16" 3/8"	2.20 13.00	0.45	1300 1	450
KFJ444HAG-B20000	KCJ444HAG-B220	412 X 305 X 356	30.0	1/2" 3/8"	2.80 17.00	0.46	1300 1	450
KFJ467HAG-B20000	KCJ467HAG-B220	458 X 302 X 380	33.5	1/2" 3/8"	3.85 23.00	0.68	1300 1	550
KFN463HAG-B30000	KCN463HAG-B330	458 X 302 X 380	24.0	3/8" 3/8"	2.70 14.00	0.68	1300 1	450
R-22 - High Temperature – Fractional Horse Power Condensing Units								
KFE443HAE-B30000	KCE443HAE-B330	457 X 305 X 343	22.0	3/8" 3/8"	2.30 13.00	0.45	1300 1	450
KFE461HAE-B30000	KCE461HAE-B470	458 X 305 X 380	26.5	3/8" 3/8"	3.10 17.00	0.68	1300 1	550
KFJ511HAE-B30000	KCJ511HAE-B420	492 X 385 X 435	40.0	5/8" 3/8"	4.70 25.00	0.87	1300 1	700

Integral Horse Power Condensing Unit

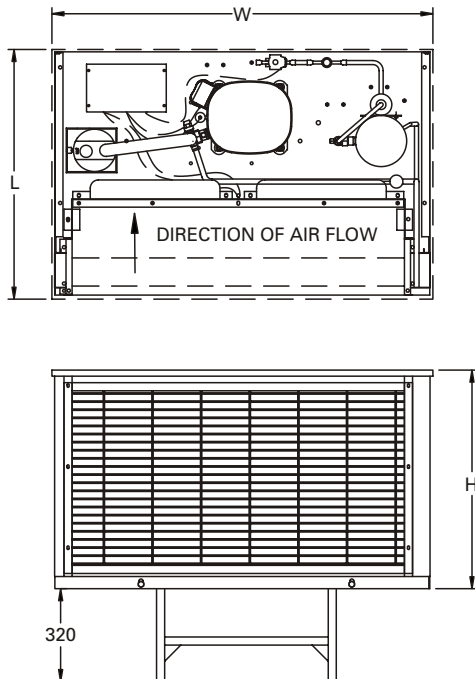

Fractional Horse Power Condensing Unit

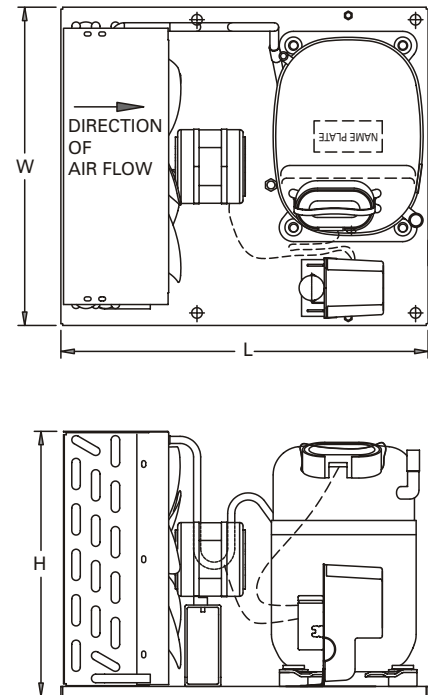

Dimensions in mm. Refer Condensing Unit Specifications for L x W x H.

Rating Conditions

Conditions	Ambient		Evaporating Temperature		Return Gas Temperature		Sub Cooling	
	°F	°C	°F	°C	°F	°C	°F	°C
High Temperature	95.0	35.0	45.0	7.2	65.0	18.3	5.0	3.0
Low Temperature	90.0	32.0	-10.0	-23.3	65.0	18.3	5.0	3.0

Notes

- Condensing Unit power consumption includes Fan motor power consumption.
- Fan Motor Power Supply for all models is 230-1Ph-50Hz
- LxWxH dimensions are shown in the dimensional drawings.
- The overall height of Condensing Unit mentioned above does not include 320mm Stand (Steel Frame).
- Operating Voltage Range:
 - For 1 phase Compressors: 180-260V, Except CR36K6-PFZ:198-264V
 - For 3 phase Compressors: 360-460V, Except CR36K6-TF5 and CR42K6-TF5:340-460V
 - For Scroll Compressor: 342-462V
- Compressor with CSR, CSIR circuit & three phase models may be used with thermostatic expansion valve. PSC circuit must use only Capillary tube as an expansion device.
- For Condensing Unit Performance Table please contact our nearest regional office.
- Cooling capacity and power consumption are nominal values at specified rating and subject to +/-5% variation.
- All Condensing Units have been tested and approved up to 46°C out-door ambient in a suitable capacity Air Conditioning appliance at Application Laboratory.

Wiring Diagrams

Fractional Horse Power Condensing Unit

Capacitor Start Capacitor Run (CSCR)

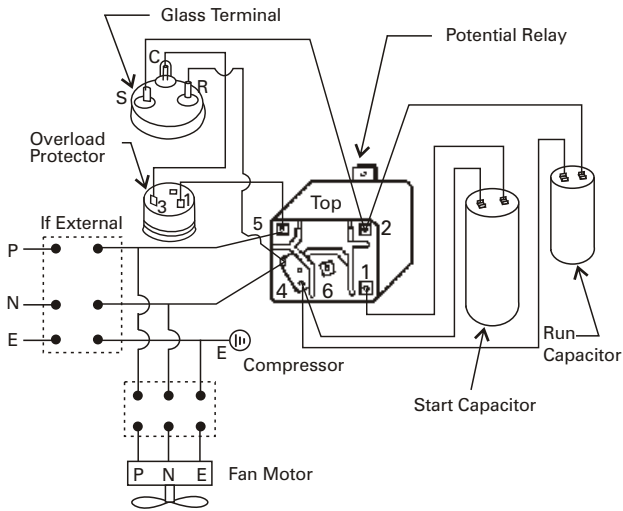

Capacitor Start Induction Run (CSIR) With Current Relay

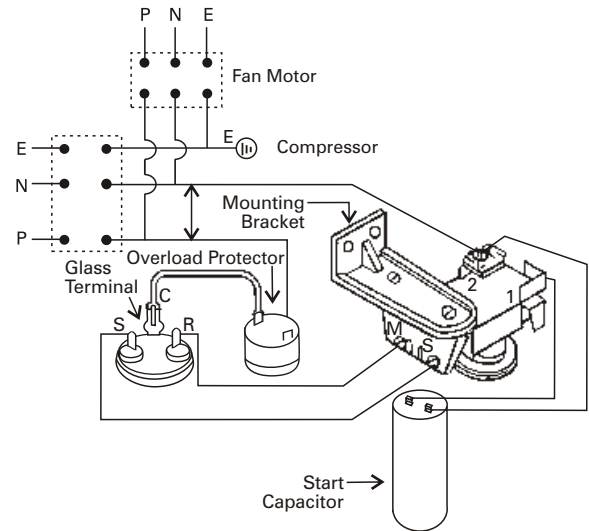

Integral Horse Power Condensing Unit

Connector Diagram

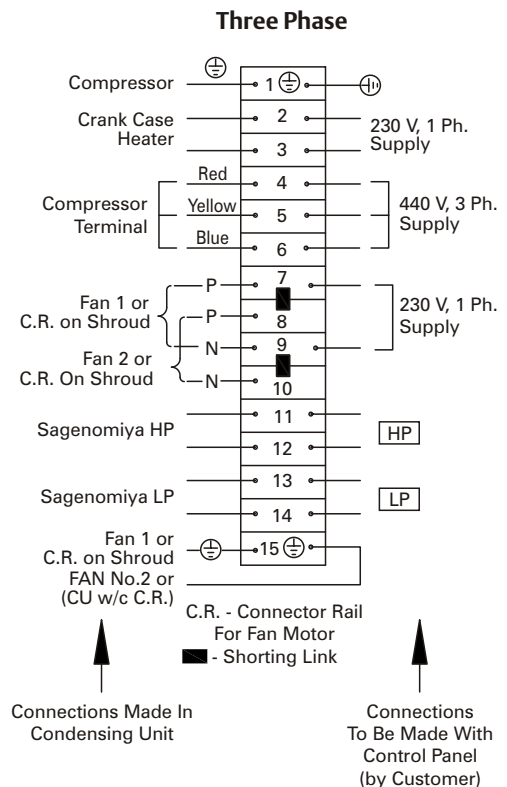
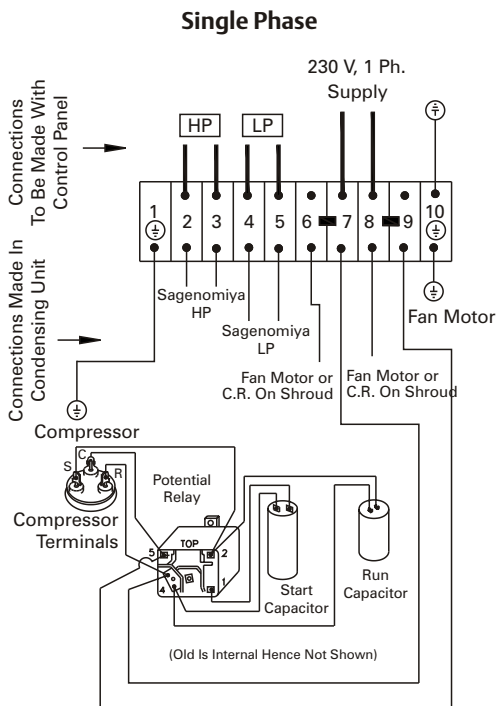

Condensing Unit Nomenclature

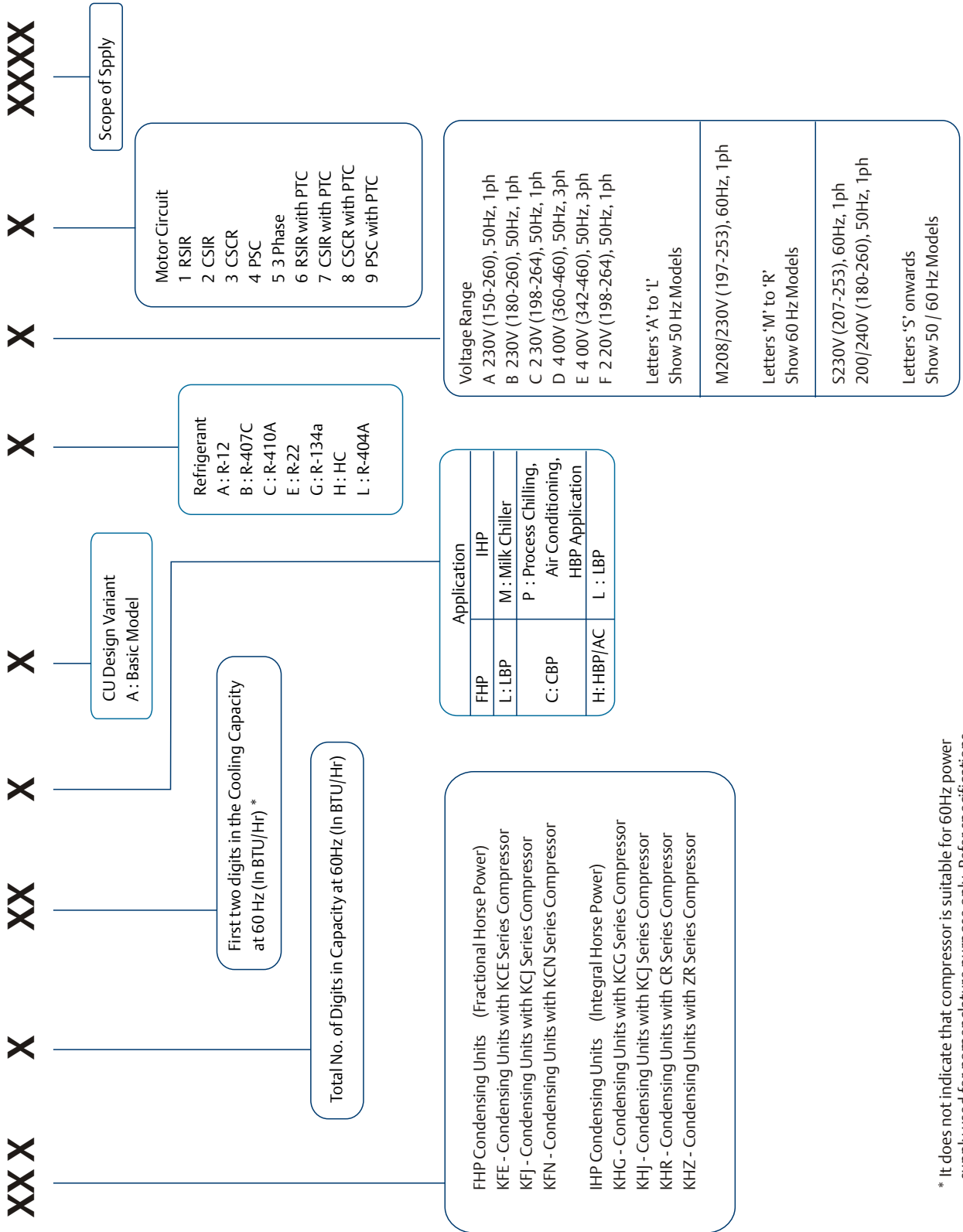

* It does not indicate that compressor is suitable for 60Hz power supply used for nomenclature purpose only. Refer specifications for power supply.

Regional Offices

Ahmedabad

Emerson Climate Technologies (India) Ltd.
3, Jayantilal Park, Near Heera Rupa Hall,
Ambli-Bhopal Road
Ahmedabad - 380 058
Gujarat
India
Tel: (91-79) 2692 6648/ 2692 6649
Fax: (91-79) 2692 2321

Bangalore

Emerson Climate Technologies (India) Ltd.
No.21, K.H.Road
Bangalore 560 027
Karnataka
India
Tel: (91-80) 2222 0327
Fax: (91-80) 2227 6280

Chennai

Emerson Climate Technologies (India) Ltd.
New No.10, Postal Colony II street
West Mambalam
Chennai 600 033
Tel: (91-44) 2371 8771/8772/8773
Fax: (91-44) 2371 8979

Faridabad

Emerson Climate Technologies (India) Ltd.
3B-3B.P., NIT
Faridabad 120 001
Haryana
Tel: (91-129) 2414581 , 2431037

Kolkotta

Emerson Climate Technologies (India) Ltd.
35/7, Tollygunje Circular Road
P.S.New Alipore
Kolkotta 700 053
West Bengal
India
Tel: (91-33) 2400 2779/2400 2781
Fax: (91-33) 2400 2784

Mumbai

Emerson Climate Technologies (India) Ltd.
Unit No. 4,5,6 & 7, Bhaveshwar Arcade
LBS Marg, Opp. Shreyas Cinema
Ghatkopar (West)
Mumbai 400 086
Maharashtra
India
Tel: (91-22) 2500 6630/ 2500 6632
Fax: (91-22) 2500 6570

Secunderabad

Emerson Climate Technologies (India) Ltd.
1141, Rashtrapathi Road
Nr. Sree Gujarati Seva Mandal
Secunderabad 500 003
Andhra Pradesh
India
Tel: (91-40) 2753 0834/0835, 5526 0411
Fax: (91-40) 2753 0832

Pune

Emerson Climate Technologies (India) Ltd.
Shop No. 1,2,3,6,7,8
S.No.55, Katraj Dehu Bypass Road
Vadgaon Budruk
Pune 411 041, India
Tel: (91-20) 24351401
Fax: (91-20) 24351501

New Delhi

Emerson Climate Technologies (India) Ltd.
56, Rama Road Industrial Area
Nr. Mahindra Showroom
New Delhi 110 015
India
Tel: (91-11) 2511 1861/1862/1863/1864
Fax: (91-11) 2545 7748

Registered Head Office

Emerson Climate Technologies (India) Limited
1202/1, Ghole Road, Pune 411 004
Tel: (91-20) 25534988/998, Fax: (91-20) 25536350

As we are constantly endeavoring to improve the performance of our models, the specifications mentioned here are subject to change from time to time.
The Emerson logo is a trademark and a service mark of Emerson Electric Co.

Out door condensing unit 020709